

**DIVISION: 03 00 00 – CONCRETE**  
**Section: 03 11 19 – Insulating Concrete Forming**

**REPORT HOLDER:**  
BuildBlock Building Systems, LLC  
9705 N Broadway Ext., Suite 150  
Oklahoma City, Oklahoma 73114  
(405) 840-3386  
[www.buildblock.com](http://www.buildblock.com)

**REPORT SUBJECT:**  
BuildBlock®, BuildLock®, and BuildRadius Insulating Concrete Forms (ICFs)

### 1.0 SCOPE OF EVALUATION

This Research Report addresses compliance with the following Codes:

- 2021, 2018, 2015, and 2012 *International Building Code*® (IBC)
- 2021, 2018, 2015, and 2012 *International Residential Code*® (IRC)
- 2020 *Florida Building Code* (FBC) (excluding High-velocity Hurricane Zones) – See Section 8.0

NOTE: This report references the most recent version of the referenced Codes. Earlier versions of the Codes may have different section numbers.

BuildBlock®, BuildLock®, and BuildRadius ICFs have been evaluated for the following properties:

- Physical properties
- Surface-burning characteristics
- Fire resistance
- Exterior walls in Types I through IV construction
- Attic and crawl space fire evaluation
- Air leakage
- Water resistance

See Table 1 for applicable Code sections related to these properties.

### 2.0 USES

BuildBlock®, BuildLock®, and BuildRadius Insulating Concrete Forms (ICFs) are used as stay-in-place formwork for structural concrete, loadbearing and non-loadbearing, below-grade and above-grade walls. The forms are used in construction of plain and reinforced concrete beams, lintels, exterior and interior walls and foundation and retaining walls. The forms may be installed in attic and crawl space applications without a covering on the interior side in accordance with Section 4.3.2. The forms may be used in fire-resistance-rated construction, provided installation is in accordance with Section 4.8. The forms may be used in Types I, II, III, or IV (noncombustible) construction when installed in accordance with

Section 4.9. The forms may be used as an air-barrier assembly in accordance with IECC Section 405.5.1.4.

### 3.0 DESCRIPTION

#### 3.1 General:

BuildBlock®, BuildLock®, and BuildRadius Insulating Concrete Forms (ICFs) consist of two 2.5 in. thick expanded polystyrene (EPS) panels separated by injection-molded polypropylene cross-ties. BuildBlock® ICFs have a preformed interlocking mechanism along the top and bottom edges, to facilitate interlocking and stacking. BuildLock® ICFs are knock-down systems, shipped as panels and webs. The forms create a monolithic wall when filled with concrete. The forms accommodate placement of reinforcement bars for below or above grade load bearing walls, beams, lintels and shear walls.

BuildBlock® ICFs come in 4, 6, 8, 10, and 12 inch widths for the following configurations: straight, 45° corner and 90° corner. The 6 and 8 inch blocks are also available in taper top and brick ledge forms. BuildLock® is available in 4, 6, 8, 10, and 12 inch widths for straight and 10 and 12 inch widths for 90° corner configurations. BuildRadius ICFs are available in 2, 4, 8, 12, 16, and 20 ft. arc forms.

See Figures 1 through 3 for illustrations of the forms. The forms are classified as a flat ICF wall system in accordance with IRC Section R608.3.1.

#### 3.2 Foam Plastic Panels:

The EPS foam plastic panels are 16 inches (406 mm) high, 48 inches long and 2-1/2 inches thick. The panels have a nominal density of 1.5 pcf and have a flame-spread index of 25 or less and a smoke-developed index of 450 or less when tested in accordance with ASTM E 84 and comply with ASTM C578 as Type II.

#### 3.3 Cross-Ties:

The polypropylene cross-ties, spaced 6 inches on center, connect the EPS panels at a fixed clear distance. The cross-tie consists of a flange portion that is embedded in the panel during the molding process, and a web portion that connects the two flanges. The cross-tie has openings to permit concrete to flow through and has slots to support horizontal steel reinforcing bars. The plastic flange of the cross-tie is recessed 1/2 inch below the surface of the panel and is used for attachment of the exterior and interior finish materials. The flange of the cross-tie is 1-1/2 inches wide by 15 inches high by 3/16 inch thick. Each cross-tie also includes two "hard point" areas, which are reinforced sections of the flange spaced 3-1/2 inches from the ends and 8 inches apart. See Figure 4.



### 3.4 Concrete:

Concrete must be normal-weight concrete complying with the applicable Code and must have a maximum aggregate size of 3/8 inch and a minimum specified compressive strength of 2,500 psi at 28 days, except as noted in Table 2 for fire-resistance-rated assemblies. Under the IRC, concrete must comply with IRC Section R404.1 (foundation walls and retaining walls) and R608.5.2 (walls), as applicable.

### 3.5 Reinforcement:

Deformed steel reinforcement bars must have a minimum specified yield stress of either 40 ksi or 60 ksi, depending on the structural design. Under the IBC, the deformed steel bars must comply with Section 3.5.3.1 of ACI 318 and IBC Section 1903. If construction is based on the IRC, reinforcement must comply with IRC Sections R404.1.3.3.7 and R608.5.2.

## 4.0 INSTALLATION

### 4.1 General:

Design and installation of BuildBlock®, BuildLock®, and BuildRadius ICFs must comply with this report, the applicable Code, and the manufacturer's published installation instructions, which must be available at the jobsite at all times during installation.

### 4.2 Design:

**4.2.1 IBC Method:** Solid concrete walls must be designed and constructed in accordance with IBC Chapter 16 and 19, as applicable. Footings and foundations must be designed in accordance with IBC Chapter 18.

**4.2.2 Alternative IBC Wind Design Method:** Solid concrete walls may be designed and constructed in accordance with the provisions of Section 209 of ICC 600, subject to the limitations found in Exception 1 of IBC Sections 1609.1.1 and 1609.1.1.1. Design and construction under the provisions of ICC 600 are limited to resisting wind forces.

**4.2.3 IRC Method:** Solid concrete walls and foundations must be designed in accordance with IRC Sections R608 and R404.1.3, as applicable for flat wall systems.

**4.2.4 Alternative IRC Methods:** When used to construct buildings that do not conform to the applicability limits of IRC Sections R404.1.3 and R608.2, construction must be in accordance with the prescriptive provisions of the 2007 Prescriptive Design of Exterior Concrete Walls (PCA 100), or the structural analysis and design of the concrete must be in accordance with ACI 318 and IBC Chapters 16, 18, and 19.

### 4.3 Interior Finish:

**4.3.1 General:** ICF units exposed to the building interior must be finished with an approved 15-minute thermal barrier, such as minimum 1/2 inch thick regular gypsum wallboard complying with ASTM C1396, installed vertically and attached to the cross-tie flanges with minimum 1-5/8 inch long, No. 6, Type W, coarse-thread gypsum wallboard screws spaced 16 inches on center vertically and 12 inches on center horizontally. The screws must penetrate a minimum of 1/4 inch through the flange. Gypsum board joints and screw heads must be taped and finished with joint compound in accordance with ASTM C840 or GA216. See Section 4.3.2 for installation details for crawl space applications without an ignition barrier on the interior face.

**4.3.2 Attic and Crawl Space Installations:** When the ICFs are used for walls of attic or crawl spaces, an ignition barrier complying with IBC Section 2603.4.1.6, or IRC Sections R316.5.3 or R316.5.4, is required, except when all of the following conditions are met:

- Entry to the attic or crawl space is only to service utilities, and no storage is permitted.
- There are no interconnected attic or basement areas.
- Air in the attic or crawl space is not circulated to other parts of the building.
- Under-floor (crawl space) ventilation is provided that complies with IBC Section 1202.4 or IRC Section R408.1, as applicable.
- Attic ventilation is provided when required by IBC Section 1202 or IRC Section R806, as applicable.
- Combustion air is provided in accordance with IMC (*International Mechanical Code*) Section 701.
- The ICFs must have at least one label as described in Section 7.0 visible in every 160 square feet of wall area.

### 4.4 Exterior Finish:

**4.4.1 Above Grade:** The exterior surface of the ICF must be covered with an approved wall covering in accordance with the applicable Code or a current evaluation report. A water-resistive barrier is not required. When the wall covering is mechanically attached to structural members, the wall covering must be attached to the flanges of the embedded cross-ties with fasteners, described in Table 3, having sufficient length to penetrate through the flange a minimum of 1/4 inch. The fasteners have an allowable fastener withdrawal and lateral shear strength as noted in Table 3. Screws placed into the BuildBlock® (BB) flange hard point areas have additional fastening withdrawal and lateral capacities as noted in Table 3.

The fastener spacing must be designed to support the gravity loads of the wall covering and to resist the negative wind pressures.

The negative wind pressure capacity of the exterior finish material must be the same as that recognized in the applicable Code for generic materials, or as recognized in a current evaluation report for proprietary materials and must not exceed the maximum withdrawal capacity of the fasteners listed in Table 3.





**4.4.2 Below Grade:** Materials used to dampproof or waterproof basement walls must be specified by BuildBlock Building Systems, LLC, and must comply with the applicable Code or a current evaluation report. The material must be compatible with the ICF foam plastic units, and free of solvents, hydrocarbons, ketones, and esters that will adversely affect the EPS foam plastic panels. Dampproofing, waterproofing, and drainage requirements must comply with the applicable Code. No backfill can be applied against the wall until the complete floor system is in place, unless the wall is designed as a freestanding wall that does not rely on the floor system for structural support.

#### 4.5 Foundation Walls:

The ICF system may be used as a foundation stem wall when supporting wood-framed or steel-framed construction, provided the structure is supported on concrete footings complying with the applicable Code. For jurisdictions adopting the IRC, compliance with Section R404 is required.

#### 4.6 Retaining Walls:

The ICF system may be used to construct retaining walls, with reinforcement designed in accordance with accepted engineering principles, Section 4.2 of this report, and the applicable Code.

#### 4.7 Protection Against Termites:

Where the probability of termite infestation is defined by the Code official as "very heavy", the foam plastic must be installed in accordance with IBC Section 2603.8 or IRC Section R318.4, as applicable. Areas of very heavy termite infestation must be determined in accordance with IBC Figure 2603.8 or IRC Figure R301.2(6).

#### 4.8 Fire-resistance-rated Construction:

The ICFs may be used to construct loadbearing and non-loadbearing fire-resistance-rated wall assemblies as described in Table 2 and Intertek Design Listing [BBS/ICF 180-01](#).

#### 4.9 Installation in Buildings Required to be of Types I, II, III, and IV Construction:

**4.9.1 General:** Exterior walls constructed with the ICFs for use in buildings required to be of Type I, II, III, or IV construction must comply with the applicable conditions cited in Sections 4.9.2 through 4.9.4.

#### 4.9.2 Interior Finish:

**4.9.2.1 Buildings of Any Height:** The ICFs must be finished on the interior with an approved 15-minute thermal barrier, such as 1/2 inch thick gypsum wallboard, as required by the IBC. The gypsum wallboard must be installed and attached as described in Section 4.3.1.

**4.9.2.2 Alternate Interior Finish for One-story Buildings:** For one-story buildings, the interior finish may be in accordance with IBC Section 2603.4.1.4, provided all the conditions in that section are met.

#### 4.9.3 Exterior Finish:

**4.9.3.1 Buildings of Any Height:** Except as allowed in Section 4.4.1, the ICFs must be finished on the exterior with materials described in Sections 4.9.3.1.1 and 4.9.3.1.2. The ICFs must have at least one label as described in Section 7.0 visible in every 160 square feet of wall area prior to applying the wall covering.

**4.9.3.1.1 Exterior Finish – EIFS and One-coat Stucco:** EIFS and one-coat stucco wall coverings may be applied over the ICF, provided the wall covering system is recognized in a current evaluation report and is recognized for use in Types I, II, III, and IV construction. The wall covering system must be installed in accordance with the respective evaluation report and the maximum mass per wall surface area (lbs/ft<sup>2</sup>) qualified in the wall covering evaluation report, must be greater than 0.312 lbs/ft<sup>2</sup> (which is the mass of the EPS panel on the exterior side of the concrete wall). Acceptable EIFS wall coverings include BASF Corporation Senerflex EIFS as recognized in ICC-ES ESR-1794.

**4.9.3.1.2 Exterior Finish – Brick Veneer:** Anchored brick veneer must be attached to the flanges of the cross-ties with fasteners as described in Section 4.4.1. The 4 inch thick brick veneer must comply with the IBC and must be installed with a minimum 1 inch air gap between the face of the exterior EPS panel and the brick. The brick must be installed with a steel shelf angle attached to the concrete and installed at each floor line and at the top of each window and door opening.

**4.9.4 Fireblocking:** For applications on buildings of any height, floor-to-wall intersections must be fireblocked in accordance with the IBC to prevent the passage of flame, smoke, and hot gases from one story to another. The foam plastic on the interior side of the exterior walls and on both sides of interior walls must be discontinuous from one story to another.

#### 4.10 Special Inspection:

**4.10.1 IBC:** Special inspection is required as noted in IBC Section 1705 for placement of reinforcing steel and concrete, and for concrete cylinder testing.

When an EIFS wall covering is applied, special inspection is required in accordance with the evaluation report on the EIFS, and with IBC Sections 1704.1 and 1705.16 is required.

**4.10.2 IRC:** For walls designed in accordance with Section 4.2.3 or PCA 100, special inspection is not required. When walls are designed in accordance with the IBC, as described in Section 4.2.4, special inspection is required as described in Section 4.10.1.





## 5.0 CONDITIONS OF USE

The BuildBlock Building Systems, LLC Insulating Concrete Forms described in this Research Report comply with, or are suitable alternatives to, what is specified in those Codes listed in Sections 1.0 of this report, subject to the following conditions:

**5.1** The ICFs must be manufactured, identified, and installed in accordance with this Research Report, the manufacturer's published installation instructions, and the applicable Code. In the event of a conflict between the manufacturer's instructions and this report, this report governs.

**5.2** When required by the Code official, calculations showing compliance with the general design requirements of the applicable Code must be submitted to the building official for approval, except where calculations are not required under IRC Section R608.1. The calculations and details must be prepared by a registered design professional where required by the statutes of the jurisdiction in which the project is to be constructed.

**5.3** When required by the Code official, calculations and details showing compliance with IRC Section R608.5.3 and R4041.3.3.6 must be submitted, establishing that the ICFs provide sufficient strength to contain concrete during placement and the cross-ties are capable of resisting the forces created by fluid pressure of fresh concrete. The calculations and details must be prepared by a registered design professional where required by the statutes of the jurisdiction in which the project is to be constructed.

**5.4** The ICFs must be separated from the building interior with an approved 15-minute thermal barrier, except for attic and crawl space construction as detailed in Section 4.3.2.

**5.5** Use of the ICF system in Types I, II, III, and IV construction must be as described in Section 4.9.

**5.6** The plastic cross-ties must be stored indoors away from direct sunlight.

**5.7** Special inspection must be provided in accordance with Section 4.10 of this report.

**5.8** The BuildBlock® ICFs are manufactured in Colorado Springs, Colorado; West Brookfield, Massachusetts; Nixa, Missouri; Saint Petersburg, Florida; McFarland, California; Post Falls, Idaho; Watertown, South Dakota; Waxahachie, Texas; and Piqua, Ohio, and are produced under a quality control program with inspections conducted by Intertek Testing Services NA Inc.

**5.9** BuildLock® ICFs are manufactured in Colorado Springs, Colorado; West Brookfield, Massachusetts; and Post Falls, Idaho.

**5.10** BuildRadius ICFs are manufactured in Nixa, Missouri.

## 6.0 SUPPORTING EVIDENCE

**6.1** Reports of tests in accordance with ASTM E283, ASTM E331, ASTM E119, and ASTM E2634-18.

**6.2** Data in accordance with the ICC-ES Acceptance Criteria for Stay-in-place, Foam Plastic Insulating Concrete Form (ICF) Systems for Solid Concrete Walls (AC353), editorially revised October 2015.

**6.3** Intertek Listing Report [BuildBlock®, BuildLock®, and BuildRadius Insulating Concrete Forms \(ICFs\)](#).

## 7.0 IDENTIFICATION

The BuildBlock®, BuildLock®, and BuildRadius Insulating Concrete Forms are identified by a label bearing the report holder's name (BuildBlock Building Systems, LLC), the manufacturing location, manufacturing date, lot number, the Intertek Mark, and the Code Compliance Research Report number (CCRR-1003).

When use is in buildings required to be of Type I, II, III, or IV construction, one label must be visible in every 160 square feet of wall area.

When the forms are used in attics or crawl spaces without an ignition barrier, the exposed inside face of the ICF must be labeled with the phrase "Suitable for use in attics and crawl spaces". The label must be visible in every 160 square feet of wall area.

## 8.0 FLORIDA BUILDING CODE

### 8.1 Scope of Evaluation:

The BuildBlock® and BuildLock® Insulating Concrete Forms (ICFs) were evaluated for compliance with the 2020 *Florida Building Code-Building*, and the 2020 *Florida Building Code-Residential*.

### 8.2 Conclusion:

The BuildBlock® and BuildLock® ICFs, described in Sections 2.0 through 7.0 comply with the 2020 *Florida Building Code-Building* and *Florida Building Code-Residential*, subject to the following conditions:

1. Applicability limits as noted in R611.2 of the 2009 *International Residential Code®* must be based on the nominal wind speed,  $V_{asd}$ , as determined by Section R301.2.1 of the *Florida Building Code-Residential*.

2. Wind loads must be determined by Section R301.2.1 of the *Florida Building Code-Residential* and Section 1609 of the *Florida Building Code-Building*, as applicable.

3. Retaining walls must meet the requirements of Section 1807.2 of the *Florida Building Code-Building*.





4. In addition to the requirements noted in the master report, termite protection must meet the requirements of Section 1816 of the *Florida Building Code-Building* and Section R318 of the *Florida Building Code-Residential*, as applicable.

5. The EIFS products noted in Section 4.9 have not been evaluated for compliance with the *Florida Building Code-Building* or the *Florida Building Code-Residential*.

6. Use of the BuildBlock® and BuildLock® ICFs for compliance with the High-Velocity Hurricane Zone provisions of the *Florida Building Code-Building* or the *Florida Building Code-Residential* has not been evaluated and is outside the scope of this evaluation report.

7. For products falling under Florida Rule 9N-3, verification that the report holder’s quality assurance program is audited by a quality assurance entity approved by the Florida Building Commission for the type of inspections being conducted is the responsibility of an

approved validation entity (or the Code official when the report holder does not possess an approval by the Commission).

8. Intertek is a Florida State Product Evaluation Entity.

**9.0 CODE COMPLIANCE RESEARCH REPORT USE**

**9.1** Approval of building products and/or materials can only be granted by a building official having legal authority in the specific jurisdiction where approval is sought.

**9.2** Code Compliance Research Reports shall not be used in any manner that implies an endorsement of the product by Intertek.

**9.3** Reference to the <https://bpdirectory.intertek.com> is recommended to ascertain the current version and status of this report.

This Code Compliance Research Report (“Report”) is for the exclusive use of Intertek’s Client and is provided pursuant to the agreement between Intertek and its Client. Intertek’s responsibility and liability are limited to the terms and conditions of the agreement. Intertek assumes no liability to any party, other than to the Client in accordance with the agreement, for any loss, expense or damage occasioned by the use of this Report. Only the Client is authorized to permit copying or distribution of this Report and then only in its entirety, and the Client shall not use the Report in a misleading manner. Client further agrees and understands that reliance upon the Report is limited to the representations made therein. The Report is not an endorsement or recommendation for use of the subject and/or product described herein. This Report is not the Intertek Listing Report covering the subject product and utilized for Intertek Certification and this Report does not represent authorization for the use of any Intertek certification marks. Any use of the Intertek name or one of its marks for the sale or advertisement of the tested material, product or service must first be approved in writing by Intertek.





TABLE 1 – PROPERTIES EVALUATED

PROPERTY	IBC SECTION	IRC SECTION	IECC SECTION
Physical Properties	NA	R404.1.3.3.6.1 and R608.4.4	NA
Surface-burning Characteristics	2603.3	R316.3	NA
Fire Resistance	703.2	R302.1	NA
Exterior Walls in Types I – IV Construction	2603.5	NA	NA
Attic and Crawl Space Applications	2603.4.1.6 and 2603.10	R316.5.3, R316.5.4 and R316.6	NA
Air Permeance	NA	NA	405.5.1.4
Water Resistance	1402.2	R703.1.1	NA

TABLE 2 – THREE HOUR FIRE-RESISTANCE-RATED WALL ASSEMBLIES<sup>4</sup>

WALL TYPE	FORM WIDTH	THERMAL BARRIER <sup>3,4</sup>	STEEL REINFORCEMENT <sup>1</sup>
Bearing <sup>1,2,3,4,5</sup> Max Load 5000 lbf/lin ft	11,13, 15, or 17 inches	½-inch gypsum wallboard fastened 12 inches oc in field and 6 inches oc at perimeter	Vertical - #5, 24 inches oc Horizontal - #5, 32 inches oc
Nonbearing <sup>2,3</sup>	11,13, 15, or 17 inches	½-inch gypsum wallboard fastened 12 inches oc in field and 6 inches oc at perimeter	Vertical - #5, 24 inches oc Horizontal - #5, 32 inches oc

For SI: 1 inch = 25.4 mm

<sup>1</sup>Steel reinforcement is the minimum required for the design loads given.

<sup>2</sup>Concrete must be normal-weight concrete (150-155 lb/ft<sup>3</sup>) with a minimum 3000 psi compressive strength.

<sup>3</sup>Fasteners to attach the gypsum wallboard thermal barrier must be 1-5/8-inch long No. 6, Type W, coarse-thread gypsum wallboard screws. See Section 4.3.1

<sup>4</sup>The wall assembly may be used as either an interior or exterior wall. When used as an interior wall, both sides of the form must be protected with gypsum wallboard.

<sup>5</sup>Design loads are based on 10-foot wall heights.

TABLE 3 – ALLOWABLE WITHDRAWAL AND LATERAL CAPACITIES OF FASTENERS IN CROSS-TIE FLANGES

FASTENER <sup>1</sup>	ALLOWABLE LOAD CAPACITY (lbf) <sup>3</sup>	
	Lateral	Withdrawal
#2 square drive, 0.120-inch, fine thread screw having average 5 threads per inch placed at any point on the flange	56	24
#2 square drive, 0.120-inch, fine thread screw having 5? threads per inch placed at center of BB Hard Point <sup>2</sup> location on the flange	56	33
No. 6, Type S, fine thread drywall screw placed at any point on the flange	54	31
No. 6, Type S, fine thread drywall screw placed at center of BB Hard Point <sup>2</sup> location on the flange	81	66

For SI: 1 lb = 4.45 N

<sup>1</sup>Fasteners must be of sufficient length to penetrate through the flange a minimum of ¼ inch.

<sup>2</sup>BB Hard Points are located at points marked “BB” on the forms, 4 inches from the top and bottom edges, at 6 inches on center horizontally. See Figure 4.

<sup>3</sup>Allowable Load Capacity is determined for lateral loads by dividing the ultimate load by a factor of 3.2 or at 75% of the proportional limit, as applicable, and for withdrawal, by dividing the ultimate load by a factor of 5.



Intertek

Version: 6 April 2017

545 E. Algonquin Road • Arlington Heights • Illinois • 60005

[intertek.com/building](http://intertek.com/building)ACCREDITED  
Product  
Certification Agency

PCA-101

SFT-CCRR-OP-40b



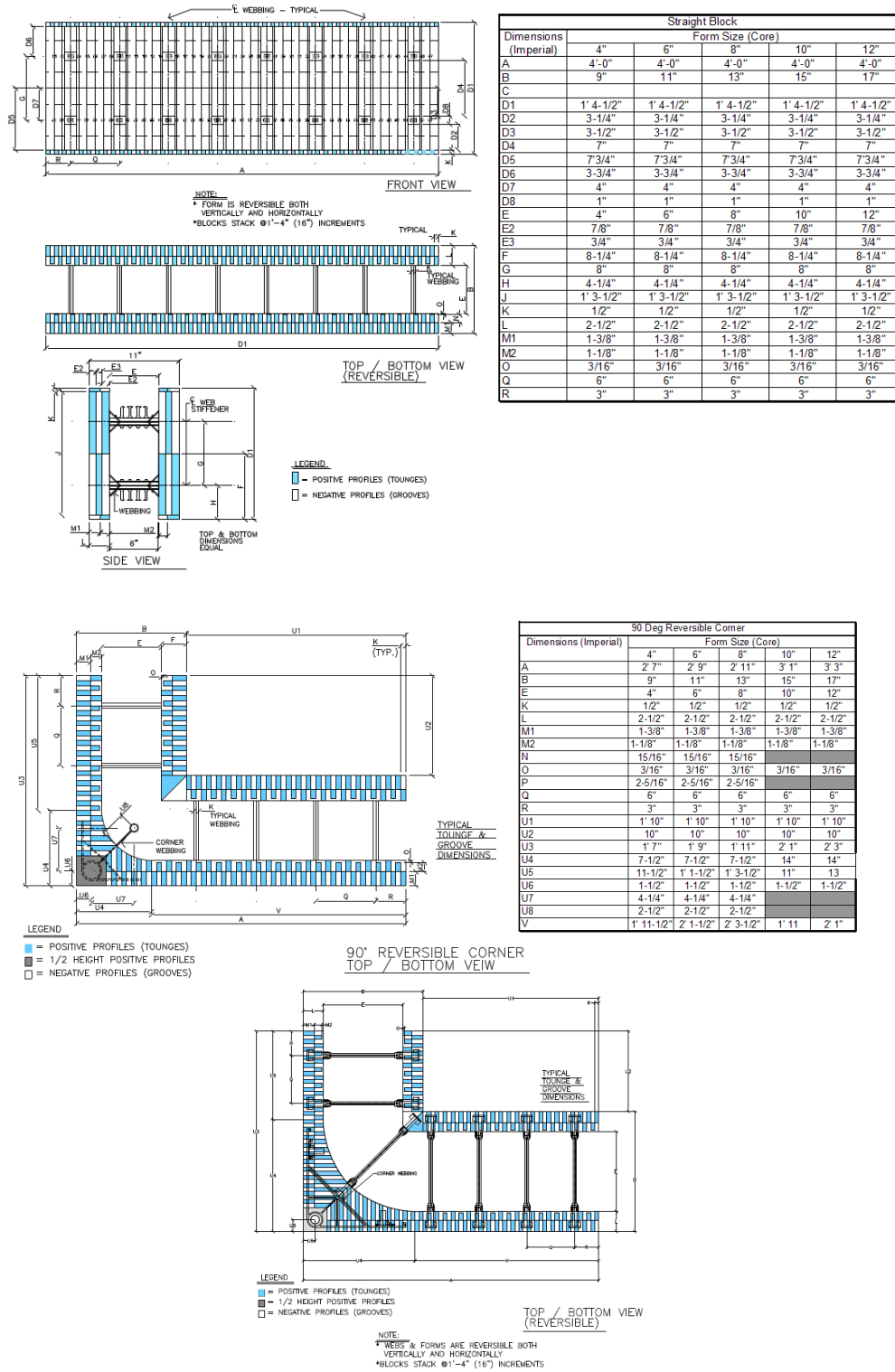

FIGURE 1A – BUILDBLOCK® AND BUILDLOCK® FORMS



Intertek

Version: 6 April 2017

545 E. Algonquin Road • Arlington Heights • Illinois • 60005

[intertek.com/building](http://intertek.com/building)



ACCREDITED

Product Certification Agency

PCA-101

SFT-CCRR-OP-40b







SPECIFICATIONS						
PRODUCT ID	BBR-602	BBR-604	BBR-608	BBR-612	BBR-616	BBR-620
90° ARC LENGTH	2ft / 60.96 cm	4ft / 121.92 cm	8ft / 243.84 cm	12ft / 365.76 cm	16ft / 487.68 cm	20ft / 609.6 cm
BLOCK ANGLE	90°	90°	22.5°	15°	11.25°	9°
OUTER ARC LENGTH	24 in / 60.96 cm	48 in / 121.92 cm	24 in / 60.96 cm	24 in / 60.96 cm	24 in / 60.96 cm	24 in / 60.96 cm
INNER ARC LENGTH	20.1875 in / 51.27 cm	30.68 in / 77.94 cm	19.75 in / 50.16 cm	21.125 in / 53.65 cm	21.8125 in / 55.40 cm	22.25 in / 56.51 cm
STRAIGHT LEG	18 in / 6 in 45.72 cm / 15.24 cm	12 in / 0 30.48 cm / 0	0	0	0	0
PANEL HEIGHT	16 in / 40.64 cm	16 in / 40.64 cm	16 in / 40.64 cm	16 in / 40.64 cm	16 in / 40.64 cm	16 in / 40.64 cm
OUTER PANEL SURFACE AREA	5.333 ft <sup>2</sup> 0.4951 m <sup>2</sup>	6.667 ft <sup>2</sup> 0.6193 m <sup>2</sup>	2.667 ft <sup>2</sup> 0.2477 m <sup>2</sup>	2.667 ft <sup>2</sup> 0.2477 m <sup>2</sup>	2.667 ft <sup>2</sup> 0.2477 m <sup>2</sup>	2.667 ft <sup>2</sup> 0.2477 m <sup>2</sup>
INNER PANEL SURFACE AREA	4.91 ft <sup>2</sup> 0.4561 m <sup>2</sup>	4.743 ft <sup>2</sup> 0.4406 m <sup>2</sup>	2.194 ft <sup>2</sup> 0.2038 m <sup>2</sup>	2.347 ft <sup>2</sup> 0.2180 m <sup>2</sup>	2.424 ft <sup>2</sup> 0.2251 m <sup>2</sup>	2.472 ft <sup>2</sup> 0.229 m <sup>2</sup>
CONCRETE VOLUME	0.056296 yd <sup>3</sup> 0.043041 m <sup>3</sup>	0.105645 yd <sup>3</sup> 0.080771 m <sup>3</sup>	0.045099 yd <sup>3</sup> 0.03448 m <sup>3</sup>	0.04642 yd <sup>3</sup> 0.035490 m <sup>3</sup>	0.04715 yd <sup>3</sup> 0.036048 m <sup>3</sup>	0.047606 yd <sup>3</sup> 0.036397 m <sup>3</sup>
OUTER DIAMETER	2.55 ft. / 30.56 in 77.2 cm	5.09 ft. / 61.12 in 155.14 cm	10.19 ft. / 122.23 in 310.59 cm	15.28 ft. / 183.35 in 465.73 cm	20.37 ft. / 244.46 in 620.88 cm	25.46 ft. / 305.58 in 776.02 cm
OUTER RADIUS	1.27 ft / 15.28 in 38.81 cm	2.55 ft / 30.56 in 77.24 cm	5.09 ft / 61.12 in 155.14 cm	7.64 ft / 91.67 in 232.87 cm	10.19 ft / 122.23 in 310.59 cm	12.73 ft / 152.79 in 388.01 cm
INNER DIAMETER	0.71 ft / 8.5 in 21.64 cm	3.26 ft / 39.125 in 99.36 cm	8.35 ft / 100.25 in 254.51 cm	13.45 ft / 161.375 in 409.96 cm	18.54 ft / 222.5 in 565.1 cm	23.63 ft / 283.625 in 720.24 cm
INNER RADIUS	0.36 ft / 10.97 cm	1.63 ft / 49.68 cm	4.18 ft / 127.41 cm	6.72 ft / 204.82 cm	9.27 ft / 282.54 cm	11.82 ft / 360.27 cm
CIRCUMFERENCE	8 ft / 2.4384 m	16 ft / 4.8768 m	32 ft / 9.7536 m	48 ft / 14.6304 m	64 ft / 19.5072 m	80 ft / 24.384 m
EPS FOAM DEPTH	2.5" / 5" Total 6.35 cm / 12.7 cm Total	2.5" / 5" Total 6.35 cm / 12.7 cm Total	2.5" / 5" Total 6.35 cm / 12.7 cm Total	2.5" / 5" Total 6.35 cm / 12.7 cm Total	2.5" / 5" Total 6.35 cm / 12.7 cm Total	2.5" / 5" Total 6.35 cm / 12.7 cm Total

FIGURE 1B – BUILDRADIUS FORMS



Intertek



ACCREDITED  
 Product  
 Certification Agency  
 PCA-101





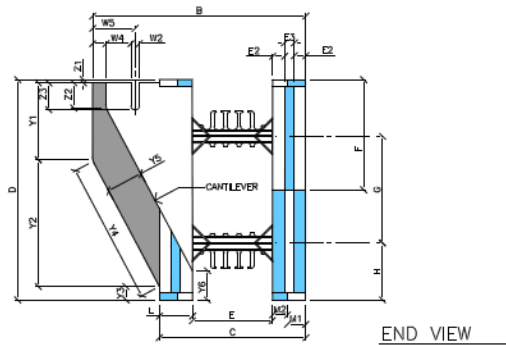
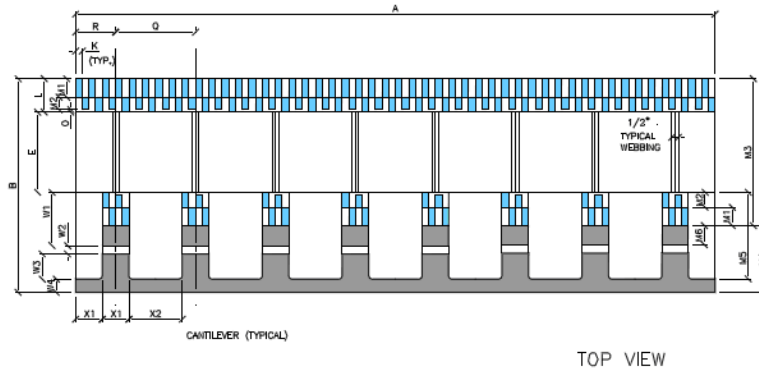

**LEGEND**  
 ■ = POSITIVE PROFILES (TOUNGES)  
 □ = NEGATIVE PROFILES (GROOVES)  
 ▬ = BASELINE

Ledge Block		
Dimensions (Imperial)	Form Size (Core)	
	6"	8"
A	4' 0"	4' 0"
B	1' 4"	1' 6"
C	11"	13"
D	1' 4-1/2"	1' 4-1/2"
E	6"	8"
E2	7/8"	7/8"
E3	3/4"	3/4"
F	8-1/4"	8-1/4"
G	8"	8"
H	4-1/4"	4-1/4"
K	1/2"	1/2"
L	2-1/2"	2-1/2"
M1	1-3/8"	1-3/8"
M2	1-1/8"	1-1/8"
M3	11"	13"
M4	5"	5"
M5	6-1/2"	6-1/2"
M6	1-7/16"	1-7/16"
O	3/16"	3/16"
P	2-5/16"	2-5/16"
Q	6"	6"
R	3"	3"
W1	4"	4"
W2	5/8"	5/8"
W3	1-7/8"	1-7/8"
W4	1"	1"
W5	3-3/16"	3-3/16"
X1	2"	2"
X2	4"	4"
Y1	5-3/4"	5-3/4"
Y2	9-1/2"	9-1/2"
Y3	1"	1"
Y4	10-5/8"	10-5/8"
Y5	2-3/4"	2-3/4"
Y6	2-3/16"	2-3/16"
Z1	1/4"	1/4"
Z2	1-7/8"	1-7/8"
Z3	2"	2"

FIGURE 1D – BUILDBLOCK® FORMS (continued)



Intertek



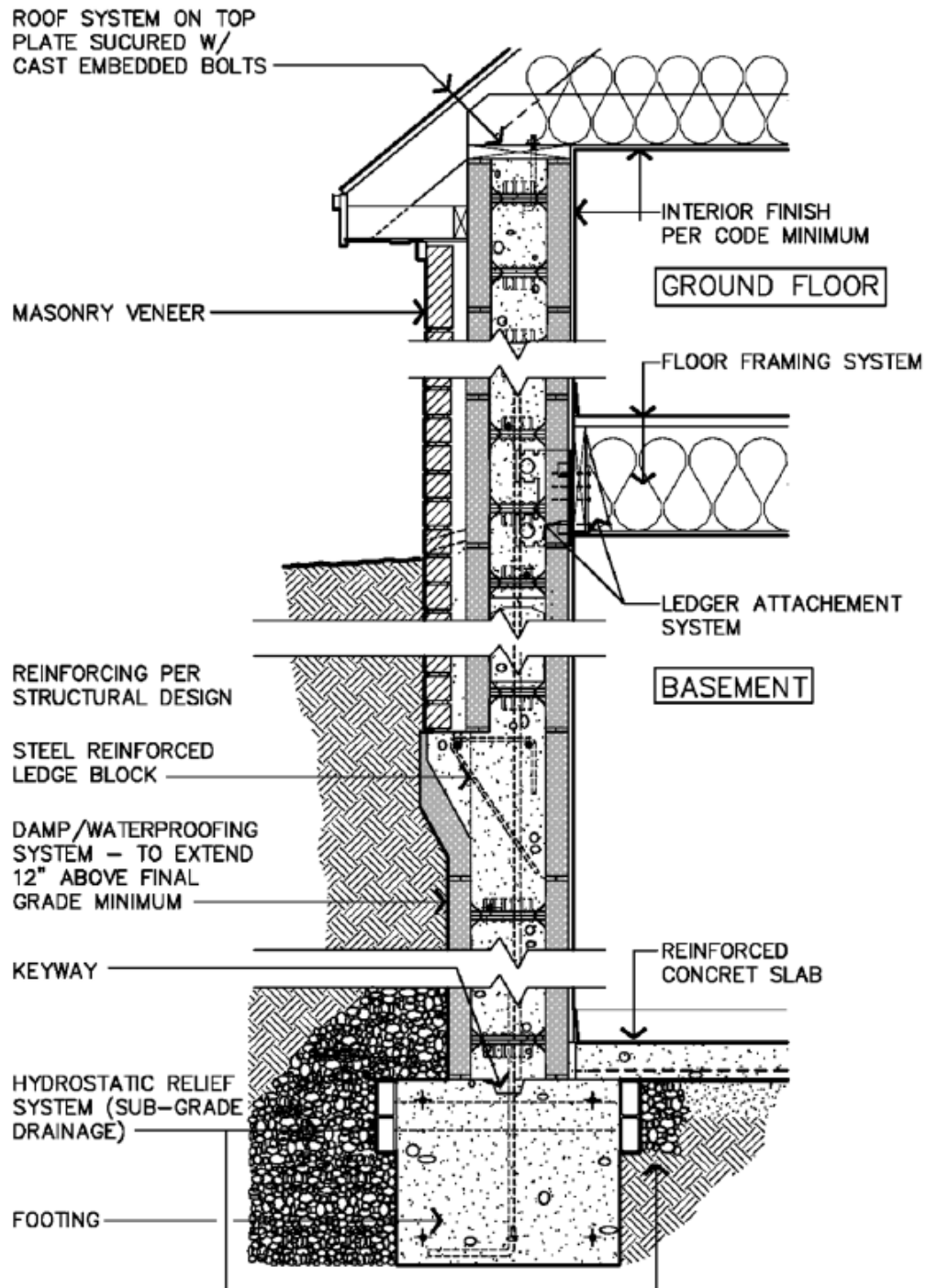

FIGURE 2 – BUILDBLOCK® AND BUILDBLOCK® BASEMENT WALL DETAIL (TYPICAL)



Intertek

Version: 6 April 2017

545 E. Algonquin Road • Arlington Heights • Illinois • 60005

[intertek.com/building](http://intertek.com/building)



ACCREDITED  
Product  
Certification Agency

PCA-101

SFT-CCRR-OP-40b

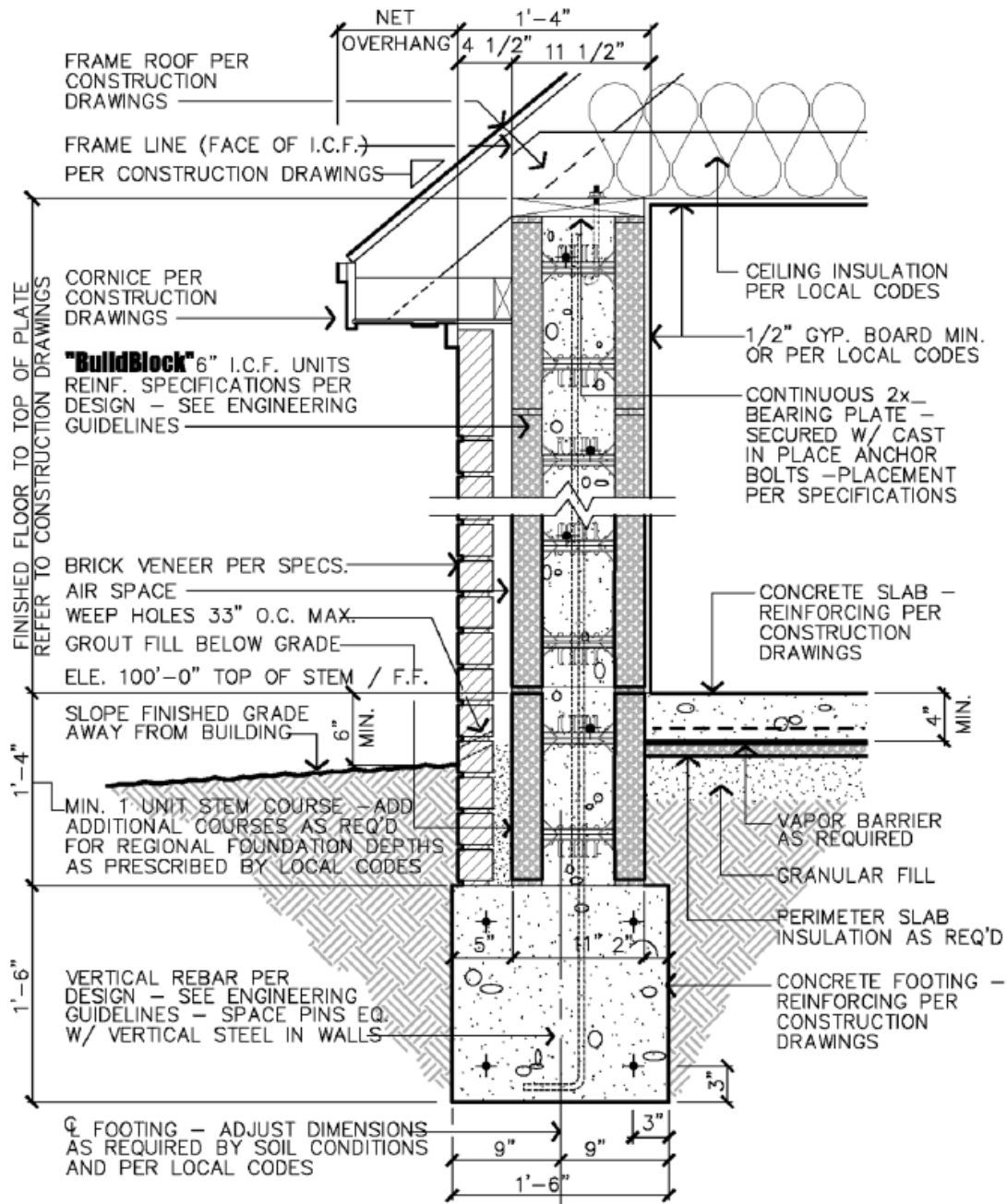

FIGURE 3 - BUILDBLOCK® AND BUILDLOCK® SINGLE STORY WALL DETAIL (TYPICAL)



Intertek

Version: 6 April 2017

545 E. Algonquin Road • Arlington Heights • Illinois • 60005

[intertek.com/building](http://intertek.com/building)



ACCREDITED  
Product  
Certification Agency

PCA-101

SFT-CCRR-OP-40b

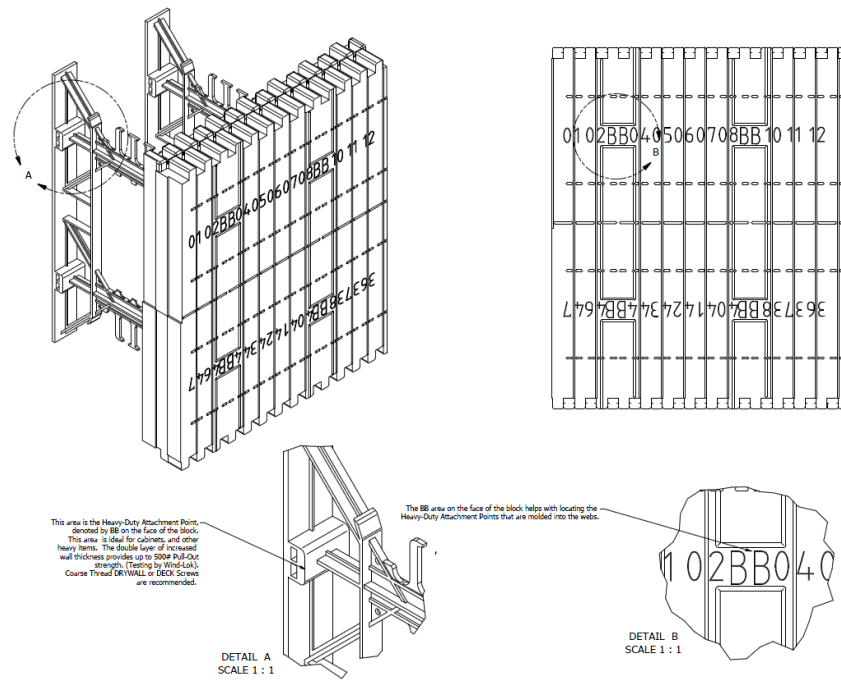

FIGURE 4 – BUILDBLOCK (BB) HARD POINT LOCATIONS



Intertek

Version: 6 April 2017

545 E. Algonquin Road • Arlington Heights • Illinois • 60005

[intertek.com/building](http://intertek.com/building)



Product Certification Agency

PCA-101

SFT-CCRR-OP-40b